



Eurovac 53 Industrial vacuum cleaner

Use- and maintenance instructions



**COMPANY WITH
QUALITY MANAGEMENT SYSTEM
CERTIFIED BY DNV GL
= ISO-9001=**

Suomen Imurikeskus Oy
Valtatie 23 1141
29630 Pomarkku

Tel. +358 (0)2 576 700
www.suomenimurikeskus.fi
eurovac@suomenimurikeskus.fi

Business ID / VAT
FI0590849

This document consist all the knowledge you need for proper use of the device. Read this guide carefully before using the device and note the warnings. Store this document carefully

This guide's content can be modified and changes can be made without notification.

Table of Contents

1. Introduction.....	4
1.1 Knowing your device, basic model.....	4
1.2 Knowing your device, trolley	5
1.3 Use features.....	5
1.4 General safety instructions	6
2. Getting started.....	6
2.1 Using the device.....	6
3. Maintenance during use	6
3.1 Emptying the trash container	7
3.2 Filter maintenance.....	7
3.3 Maintenance of cleaning kit	7
3.4 Regular spare parts.....	8
4. Troubleshooting.....	8
6. Using cyclone separator	8
7. Warranty.....	9
8. Compatible standards.....	10

1. Introduction

Congratulations, you have bought yourself a good quality industrial vacuum cleaner. We hope it's going to serve you long, That's why we advice you to use and maintenance the device properly.

We ask you to read instructions carefully before use to make sure your industrial vacuum cleaner's good operation and safety. This guide suits all electric powered Eurovac 53 industrial vacuum cleaners, unless stated otherwise. This guide doesn't suit pneumatic powered Eurovac 53 industrial vacuum cleaners.

After receiving the device check, that device hasn't damaged in shipment, and all accessories are present. If something is missing, we advice you to report the device supplier immediately, or at least in 8 days.

1.1 Knowing your device, basic model

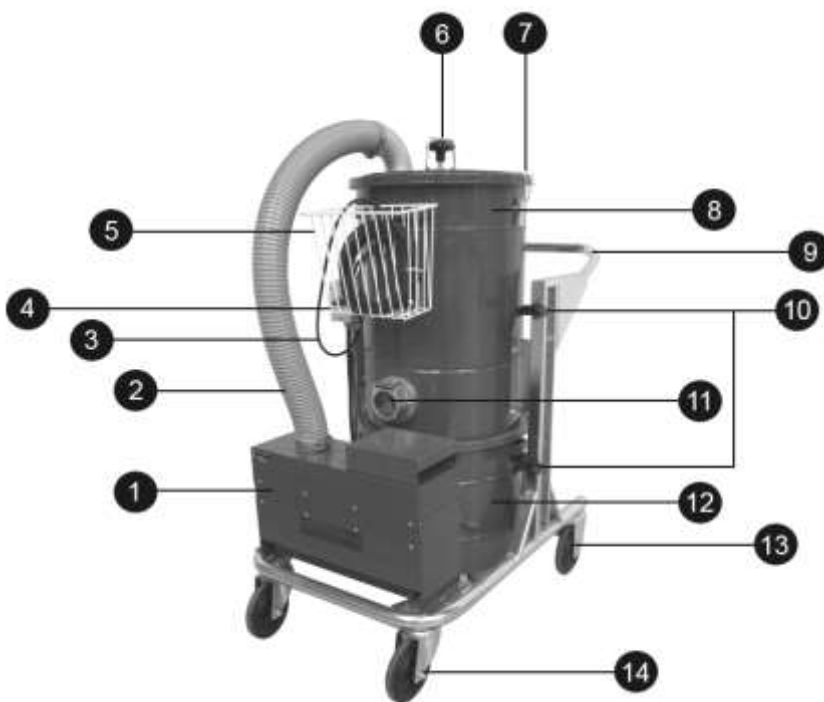

- | | |
|----------------------------------|---------------------------|
| 1. Electric unit | 8. Filter |
| 2. Tube | 9. Pushing handle |
| 3. Electric cable | 10. Cleaning kit holder |
| 4. Power switch | 11. Vacuum tube connector |
| 5. Accessory basket | 12. Trash container |
| 6. Filter shaking rod | 13. Wheel |
| 7. Filter unit's deck lock hatch | 14. Turning wheel |

1.2 Knowing your device, 53 trolley

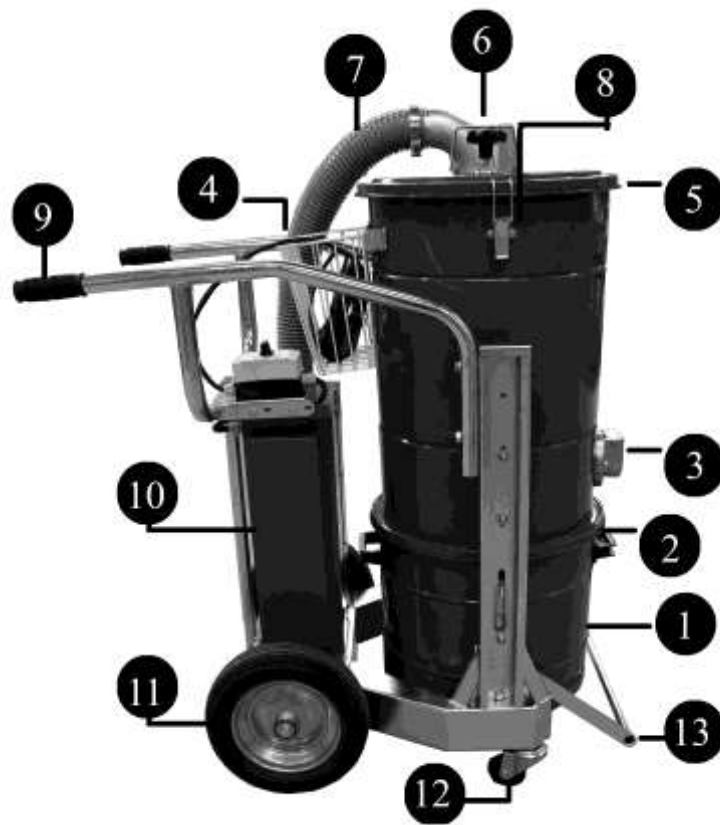

- | | |
|---------------------------|--------------------------------------|
| 1. Trash container | 8. Filtering unit's locking latch |
| 2. Trash container handle | 9. Handle |
| 3. Suction hose connector | 10. Suction unit |
| 4. Equipment basket | 11. Wheel |
| 5. Filter unit lid | 12. Rotating wheel |
| 6. Filter Shaking rod | 13. Trash container's emptying lever |
| 7. Hose | |

1.3 Use features

Eurovac 53 industrial vacuum cleaners suit dry and wet trash. If dust is very fine or other way problematic, external cyclone separator can be used before vacuum cleaner, which prevent actual vacuum cleaner getting stuck, or protect vacuum cleaner from hot ash or glowing materials.

NOTICE! Device can be used to vacuum hot ash only when using cyclone separator.

Use of cyclone separator is detailed in chapter 6.

1.4 General safety instructions

Please follow next safety instructions while using your Eurovac 53 industrial vacuum cleaner:

- Don't use vacuum-cleaner in places, which might have easily flammable gases or substances.
- Don't use vacuum cleaner to vacuum burning liquids, exploding substances or hot ash.
- Before upkeep operations, remove plug from power outlet.
- During vacuuming, be careful, that vacuum tube doesn't get close to sensitive areas of skin (eyes, mouth, ears).
- Don't vacuum in rain, or under splashing water.

2. Getting started

Before using the vacuum cleaner CHECK, that:

- Voltage you're going to use is same as the vacuum cleaner is needs (240V). Power plug must be safe grounded
- Power outlet, power plug and electric wire are intact.
- Check, that vacuum-cleaners filter is in place, and its clean and in shape after former use. Also check, that filters rail is locked with clamping device placed in vacuum cleaner's lid.

2.1 Using the device

When you're starting the vacuum cleaner, turn engines on one at the time, by turning switch first to 1 and then 2 position. When you're vacuuming wet trash or fluids, check often enough that too much water doesn't accumulate in trash container, when it would get through filters to motors and break them.

NOTICE! Device must be stored in dry and preferably warm room.

NOTICE! When vacuuming hot ash, always use cyclone separator

NOTICE! Device's noise level is 84 dB(A).

Trash container's fulfillment must be observed time to time depending on vacuumed material.



3. Maintenance during use

Next chapters insist maintenance operations, which should be done often enough to ensure long life of vacuum motors. If suction power weakens, clean filter by shaking from filter shaking rod and if necessary change it to new. Filter's integrity should be checked always when emptying the trash container.

NOTICE! Never use broken filter!

NOTICE! Remove electric cable from power outlet before maintenance operations.

3.1 Emptying the trash container

Always remember to check time to time, that trash container haven't overfilled. Eurovac 53 industrial vacuum cleaner's trash container's emptying depending on model is instructed next.

Container is emptied by lifting trash container's holder handle upwards, when container detaches and is easy to empty. When you've emptied the container, set container to it's place back to holder handle clamps and lock the container by pressing handle downwards.

NOTICE! Aina ennen roskasäiliön irrottamista sammuta laite.

NOTICE! Imuroitaessa kosteaa likaa, tai nesteitä, tarkistakaa tarpeeksi usein, ettei säiliöön kerry liikaa nestettä, jolloin se pääsisi suodattimien läpi moottoreihin ja vioittaisi niitä.

Some models of Eurovac 53 industrial vacuum cleaner series is equipped with rod which can be used to lift vacuum cleaner with for example. forklift.



3.2 Filter maintenance

Filter is cleaned by shaking from filter shaking rod or if filter is very dirty, by brushing, by blowing with pneumatic or by washing with mild water (40°C). When filter is clean, you acquire best vacuum power and save vacuum motors same time. Cleaning vacuum cleaner from dust and dirt extends vacuum motors life significantly.

NOTICE! Don't use filter which is wet after washing!

NOTICE! Make sure, that filter is set properly to its place

NOTICE! Check, that filter's shaking rod is locked to bottom with lock in vacuum cleaner's up deck.



3.3 Maintenance of cleaning kit

Also cleaning kit need cleaning time to time. Prickles can be cleaned by simply vacuuming using for example. slit nozzle.

3.4 Regular spare parts

Code	Description	Additional details
013069	Star filter 53	
013302	Star filter 53 tetratex	optional
015039	Vacuum motor's carbon	
034337	Twist switch with casing	
015004	Vacuum motor 1300 w model F	

4. Troubleshooting

Device won't turn on

- Check, that switch/switches are in position "1".
- Check, that electric cable is plugged (grounded, 230V)
- Check fuses 16 A

There's dust / dirt in output air

- Filter might be broken
- Filter isn't in place

Vacuum cleaner sounds weird

- Motor carbons are worn out
- bearings are worn out

Weak vacuum power

- Check filter's cleanliness and integrity
- Check if vacuum tube is stuck
- All motors aren't switched on

Fuse burns

- Check, that fuse is right and
- Take contact to manufacturer or seller

In problem situations, take contact to manufacturer or seller.

6. Using cyclone separator

When barrel-vacuum cleaner is equipped with second 200l container with cyclone separator lid deck, device works with pre separator principle.

When using cyclone separator, most of the dust accumulate to first barrel.



NOTICE! Glowing and burning and especially hot and burning material aren't recommended to vacuum mixed.

When you're vacuuming hot ash, vacuuming must be done in sequences to prevent vacuum tubes from melting. Vacuum ash for about 3 seconds, then give 5 seconds cool air outside ash space to vacuum cleaner.

NOTICE! Obey fire safety terms when operating with the device.

NOTICE! Notice order of tubes going to cyclone separator

7. Warranty

Suomen Imurikeskus Oy gives twelve (12) months warranty to this device with following terms. Warranty applies to material- and manufacturing flaws. Warranty might end if device is modified it changes owner or it's serviced in non-authorized service business.

WARRANTY TERMS

1. Warranty begins when device is delivered to customer and seller's ticket is enough for warranty certificate.
2. If device is serviced in warranty service, warranty won't extend. It begins when vacuum cleaner is delivered to customer and ends twelve (12) months later.
3. Warranty won't include following matters:
 - consuming parts, prickles, motor carbons, bearings, filter etc.
 - If device is used without following use- and install- instructions or filter.
 - Warranty won't include parts broken from lightning or over voltage.
 - transport-, install-, service-, etc. costs
 - reckless use, transport damages or other accident's caused damages.
 - wrong use or –install caused damages

8. Compatible standards

Common agreement terms are being followed unless there are other specific agreements. If device won't function as it's supposed to work, be in contact with seller or manufacturer.

Manufacturer:Suomen Imurikeskus Oy

Valtatie 23 1141

28630 Pomarkku

Puh. 02 5767 00

Fax. 02 5767010

www.suomenimurikeskus.fi

DECLARATION OF CONFORMITY:

WE

Suomen Imurikeskus Oy

Valtatie 23 1141

29630 Pomarkku

Assure you, that

Eurovac 53 industrial vacuum cleaner

Is designed and manufactured by following specifications :

Machine directive 89/392/EEC EN 292-1, EN 292-2

Low voltage directive 73/23/EEC EN 60 335-1

NOTE! Declaration of conformity isn't valid if:

Device has been modified without manufacturer's permission.

Device has been serviced with other than genuine spare parts