

Suomen



IMURIKESKUS

Hurricane 32 and 42

Use- and maintenance instructions

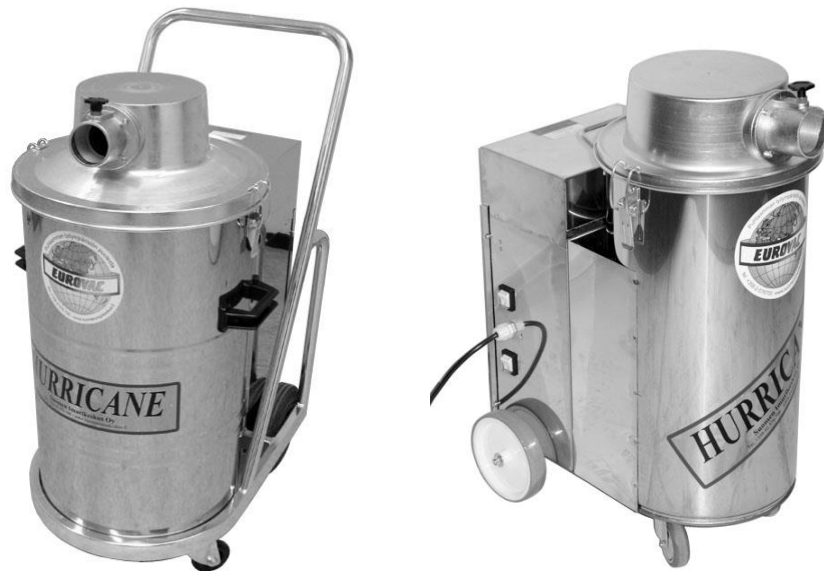

This document consist all the knowledge you need for proper use of the device. Read this guide carefully before using the device and note the warnings. Store this document carefully

This guide's content can be modified and changes can be made without notification.

Table of Contents

1. Introduction	4
1.1 Features	4
1.2 General safety instructions	4
1.3 Using the device	4
2. Maintenance	5
2.1 Maintenance during use	5
2.2 Emptying trash container and changing trash bag	6
2.3 Changing filter	6
2.4 Scheduled maintenance	6
2.5 Common spare parts	7
3. Troubleshooting	7
4. HEPA-cartridge filter installation.....	8
5. Parts list	9
6. Compatible standards	10

1. Introduction

Congratulations, you have bought yourself a good quality industrial vacuum cleaner. We hope it's going to serve you long, that's why we advise you to use and maintenance the device properly.

We ask you to read instructions carefully before use to make sure your industrial vacuum cleaner's good operation and safety. This guide suits for Hurricane 32 and 42 fine dust vacuum cleaners.

After receiving the device check, that device hasn't damaged in shipment, and all accessories are present. If something is missing, we advise you to report the device supplier immediately or at least in 8 days.

1.1 Features

Vacuum cleaner's filtering system parts are:

- Raw trash emptying container
- Silicon saturated polyester bag filter
- Fiber cloth bag inside filter bag

Accessories:

- Filter bag Tetraflex/teflon cloth
- HEPA-Filters

NOTICE! Vacuum cleaner can only be used to vacuum dry trash.

1.2 General safety instructions

Please follow next safety instructions while using your Eurovac 53 industrial vacuum cleaner:

- Don't use vacuum-cleaner in places, which might have easily flammable gases or substances.
- Don't use vacuum cleaner to vacuum burning liquids, exploding substances or hot ash.
- Before upkeep operations, remove plug from power outlet.
- During vacuuming, be careful, that vacuum tube doesn't get close to sensitive areas of skin (eyes, mouth, ears).
- Don't vacuum in rain, or under splashing water.

1.3 Using the device

Before using the vacuum cleaner CHECK, that:

- Voltage you're going to use is same as the vacuum cleaner is needs (240V). Power plug must be safe grounded
- Power outlet, power plug and electric wire are intact.

NOTICE! Device's noise level is 84 dB (A).

Turn vacuum cleaner on from switch on the side of vacuum cleaner (23). Both motors must be turned on when vacuuming. Look, that filters are in place and intact. Check often enough that trash container haven't overfilled.

NOTICE! If you notice decreasing vacuum power, empty the trash container.

NOTICE! If you use vacuum cleaner in dusty environment, clean vacuum cleaner also externally.

Also motor enclosure is necessary to clean time to time.

Notifications

- Manufacturer doesn't recommend using device with floor grinding machines without accessory filters.
- Following filters must always be in place (in order from top to down), raw trash container (1), fiber filter blue (3) Felt filter (5)
- Don't expose vacuum unit to water or humidity
- Plug device only into grounded power outlet.
- Don't use device if power plug isn't intact
- Don't pull or lift device from electric wire, use wire as lifting handle or pull electric wire over sharp edge.
- Remove electric by pulling from plug.
- Keep electric wire away from hot surfaces.
- Don't leave device plugged to power outlet when you're not using it.
- Don't touch plug or electric wire with wet hands.
- While vacuuming be careful, that vacuum tube doesn't get close to sensitive areas of skin (face).
- Be careful while using vacuum cleaner near kids. Don't let kids use vacuum cleaner as a toy.
- Before servicing vacuum cleaner, remove plug from power outlet.
- If device isn't working correctly, take contact to authorized service
- Ensure safety if device is dropped, left out, dropped in water or other accident has happened (take contact to authorized service).

2. Maintenance

Following chapters introduce necessary maintenance operations to ensure vacuum cleaner's long life.

2.1 Maintenance during use

When device is serviced, all switches must be turned to "0" position" and electric wire detached.

If you notice decreasing vacuum power, turn of motors immediately. Empty raw trash container and change fiber bag to new. Clean the felt filter and change it to new if needed.

If there's dust in output air, turn off the device and check filters immediately. If filters are somehow damaged, change it immediately to new and take contact to seller.

2.2 Emptying trash container and changing trash bag

Vacuum cleaner's filter unit and trash container's filling is necessary to be observed time to time to define right emptying sequence.

Trash container's emptying is begin by opening fasten hatches and lifting vacuum deck off the container.

When vacuum deck is lift off, raw dust container can be lift off and eptied from raw trash.

Remove trash container's support ring and lift off the dust bag and change it to new.



2.3 Changing filter

After every use it is good to clean vacuum cleaner and filters from dust and dirt and if necessary change them to new. It is recommended to check filters integrity always when emptying trash container. If filter is damaged, change it to new.



When filter is clean, best vacuum power is achieved. Also vacuum motors last longer. Filter can be washed in max 40°C water.



NOTICE! Never use wet filter after washing

NOTICE! Never use device without filter



2.4 Scheduled maintenance

- Scheduled maintenance should be done depending on use environment
- Vacuum cleaner's condition should be observed to define right sequence.
- Scheduled maintenance includes filter and accessory condition check and device cleaning.
- Motor carbons should be checked often enough and changed to new. Approximate life of carbons is 400 h, depending on environment.
- Filter's condition must be checked while emptying trash container.
- While observing filter, clean trash container from trash from bottom.
- If felt filter is dirty, clean it by brushing, with pneumatic air or if necessary washing
- If necessary change filter to new (broken, worn out, stuck)
- Fiber bag must be changed to new always when emptying the vacuum cleaner

NOTICE! Only use original genuine Eurovac filters and spare parts. Replicas can cause vacuum cleaner break down and warranty will end.

2.5 Common spare parts

Koodi	Kuvaus	Lisätiedot
013071	Filter bag Hurricane 32	
013036	Filter bag Hurricane 42	
015036	Vacuum motors carbon	carbon pair
013060	Dust bag Hurricane 32	
013061	Dust bag Hurricane 42	

3. Troubleshooting

Device won't turn on

- Check, that switch/switches are in position "1".
- Check, that electric cable is plugged (grounded, 240V)
- Check fuses 16 A

There's dust / dirt in output air

- Filter might be broken
- Filter isn't in place

Vacuum cleaner sounds weird

- Motor carbons are worn out
- bearings are worn out

Weak vacuum power

- Check filter's cleanliness and integrity
- Check if vacuum tube is stuck
- All motors aren't switched on

Fuse burns

- Check, that fuse is right and big enough
- Take contact to manufacturer or seller

In problem situations, take contact to manufacturer or seller.

Device has 12 months warranty of manufacturing- and material flaws.

In problem situations, take contact to seller.

4. HEPA-cartridge filter installation

Before install it's good to open vacuum cleaner's back deck, so you can clean dropping staple's pieces from motor space. These pieces can easily break motors. Back deck is fastened with four screws.

Detach blowing deck which is fastened with four staples with 3mm drill.

Check that pieces of staples won't remain in motor space.

HEPA-cartridges are in ready package:

- 2 pcs cartridge filters
- 2 pcs fasten baskets
- 2 pcs star knobs
- 2 pcs collar connectors
- 1 pcs nailing platform
- 2 pcs seals

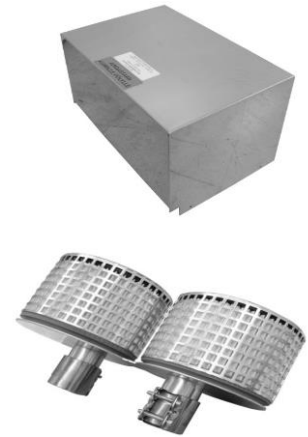

Packet is installed in place of removed blowing deck

Under removed blowing deck appear two grey plastic pipes where cartridge filter is installed with collar connectors.



Press packet to its place and fasten screws with allen wrench. Don't press too much so plastic pipes don't push inside vacuum cleaner. Close back deck.

If packet doesn't go on it's place easily, lubricant can be used.

Filter cartridge is good to clean time to time. Open star knobs, take off the baskets, take cartridges and clean with pneumatic

Picture shows ready Hurricane with HEPA-cartridges.

Blowing deck can be set back to it's place if HEPA cartridges are removed.

5. Parts list

Hurricane 42

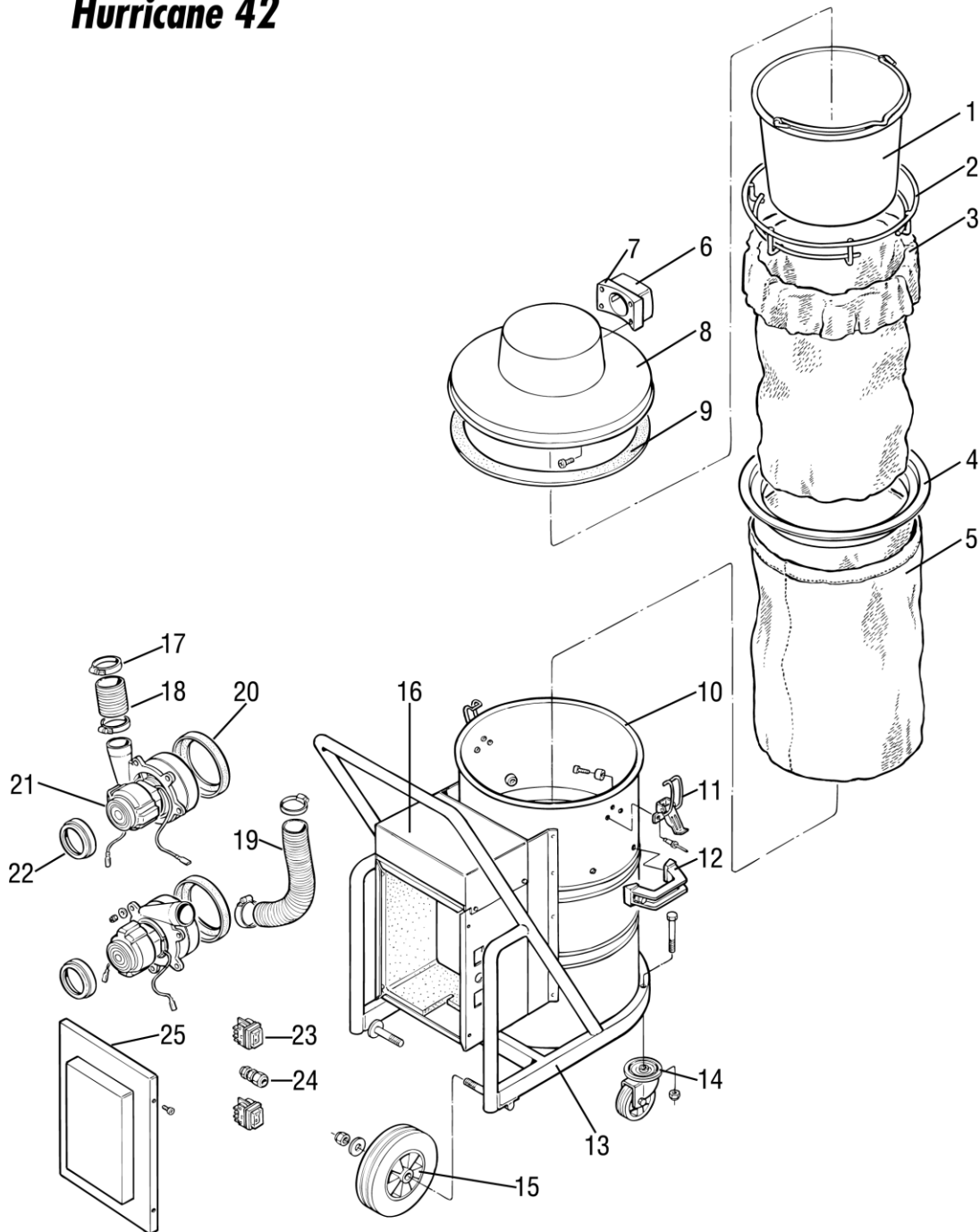

- | | |
|--|-----------------------------------|
| 1. Raw dust separator | 13. Body platform |
| 2. Support ring | 14. Turning front wheel |
| 3. Disposable filter | 15. Rear wheel |
| 4. Filter's support ring | 16. Blowing case |
| 5. Polyester filter cloth | 17. Tighten clip 50 mm |
| 6. Tube hole 58 mm | 18. Output pipe short |
| 7. Tube hole seal | 19. Output pipe long |
| 8. Vacuum deck, metallic | 20. Motor plastic seal |
| 9. Vacuum deck plastic seal | 21. Vacuum motor 1300 w |
| 10. Container 82 litre + motor enclosure | 22. Motor stand |
| 11. Deck fasten latch, metallic | 23. Switch |
| 12. Lift handle | 24. Electric cable's pull remover |
| | 25. Motor enclosure back deck |

6. Compatible standards

The device is CE approved

Dispatch follows general agreement unless otherwise agreed. If device isn't working properly, take contact to seller or device manufacturer.

Manufacturer:

Suomen Imurikeskus Oy

Valtatie 23 1141

29630 Pomarkku, FINLAND

Puh. 02 5767 00

Fax. 02 5767010

www.suomenimurikeskus.fi

DECLARATION OF CONFORMITY

Suomen Imurikeskus Oy

Valtatie 23 1141

29630 Pomarkku, FINLAND

Assure that:

Eurovac Hurricane 32 / 42 vacuum cleaner

Is designed and manufactured under following specifications

Machine directive; 89/392/EEC

Standards: SFS-EN ISO 12100-1, SFS-EN ISO12100-2

Low voltage directive; 73/23/EEC

Standard: EN 60 335-1

NOTICE! Declaration of conformity will void if device is serviced against instructions with other than Eurovac genuine spare parts or device has been modified.